



Cesco

Hydraulic Transit Mixer Trailer Mixer



Quality
ISO 9001



STANDARD MIXER	OPTIONS
<ul style="list-style-type: none"> ❖ Barrel with 8mm reinforced dished end ❖ Feed chute, swivel chute ❖ Aluminium slide up ladder ❖ Gearbox ZF7300 ❖ Rexroth pump and motor ❖ Poly guards ❖ 2 x poly extension chutes, 1 x poly placement chute ❖ Remote controls ❖ Steel trunnion rollers ❖ Double acting or remote chute jack ❖ 300L pressurised water system ❖ Painted in polyurethane paint – one colour barrel one colour frame 	<ul style="list-style-type: none"> ❖ 2 colour barrel ❖ Water meter ❖ Slump meter

EPB 0187
Issue date: 16/06/2010

Cesco Australia Limited

Brisbane:	Head Office:	38 Goodman Place Murarrie Qld 4172	Ph: (07) 3908 6088	Fax: (07) 3390 6898
Brisbane:	Mixer Service Centre	38 Goodman Place Murarrie Qld 4172	Ph: (07) 3908 6088	Fax: (07) 3390 6898
Gold Coast	Mixer Service Centre	Unit 2, 1/31 Rudman Pde. Andrews Qld 4220	Ph: (07) 5593 7066	Fax: (07) 5593 7477
Melbourne:	Mixer Service Centre:	76-78 Hallam South Road Hallam Vic 3903	Ph: (03) 9796 4977	Fax: (03) 9796 4811

Authorised Distributor

Sydney:	Davcron Engineering.:	5 Tennyson Street Granville NSW 2142	Ph: (02) 9637 8186	Fax: (02) 9637 5184
Perth:	Precedence Eng.	10 Drummond Place West Perth WA 6005	Ph: (08) 9328 4818	Fax: (08) 9328 9786

Authorised Agent

Adelaide:	Marleston Eng.	40 Manchester Street Mile End SA 5031	Ph: (08) 8443 6766	Fax: (08) 8443 6832
-----------	----------------	---------------------------------------	--------------------	---------------------

Specification: Cesco Hydraulic Transit Mixer 10m³ Trailer

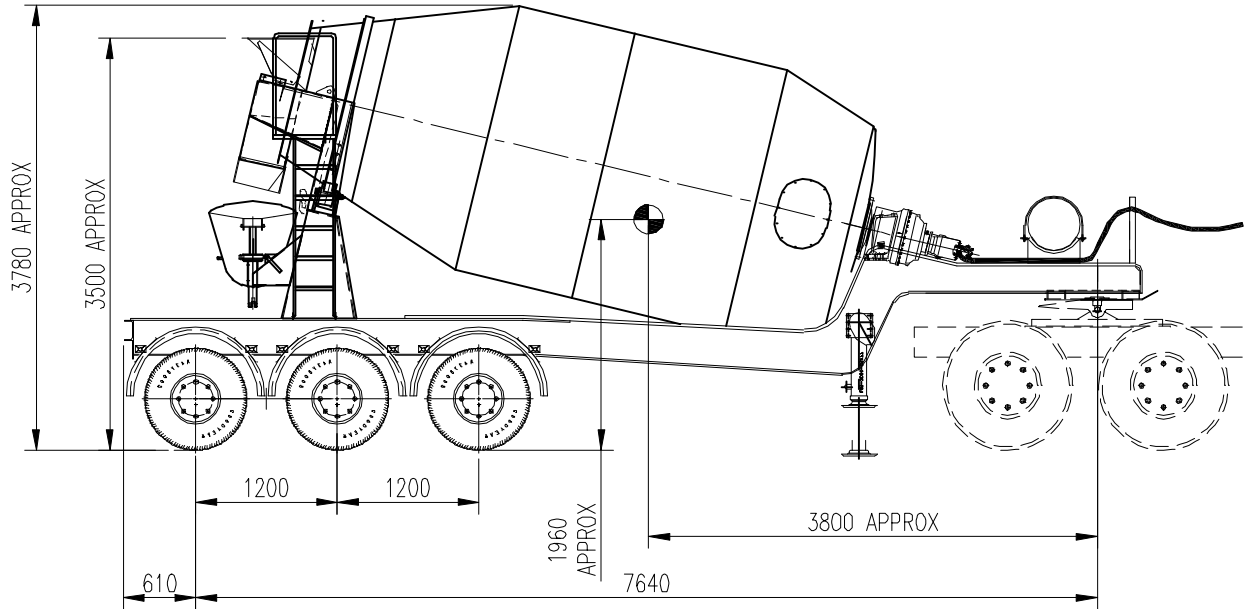

Item	Dim.	Description	10 m ³
2		Total Barrel Volume	16.2 m ³
3		Mixing Capacity to AS1379 - 2007	10 m ³
7		Water System	300 litre alloy p.w.s.
8		Controls	Remote
9		Trunnion Rollers	Steel
10		Chutes – 2 x Extension, 1 x Placement	Poly
11		Barrel Specification:	
12		Dished End	8mm High tensile
13		Back Cone	5mm High tensile
14		Centre Band	5mm High tensile
15		Nose Cone	5mm High tensile
16		Mix Blades	5mm High tensile
		Discharge. Blades	3mm High Tensile

Note: Specifications and mixer layout are for references only and subject to actual applications and components availability.

Advances in design or improvements in materials are incorporated without delay, consequently we reserve the right to alter details given on this specification sheet without notice. Operating weight and centre of gravity may vary depending on selected options.

Visit our website: www.cescoaustralia.com

A member of the  ZICOM GROUP