

CESCO AUSTRALIA LTD

STEERABLE "SUPA MAXI"



STANDARD STEERABLE TRAILER MIXER	OPTIONS
<ul style="list-style-type: none"> ❖ Barrel with 8mm dished end ❖ Feed chute, Swivel chute ❖ Fold Down access ladder both sides ❖ Gearbox ZF7300 ❖ 130/75 pump and motor, slump gauge ❖ Pressed Ally chequer plate guards ❖ 2 x poly extension chutes, 1 x poly placement chute ❖ Remote controls ❖ 4 x Steel rollers ❖ Remote operated [up and down] hydraulic chute jack ❖ 200L pressurised ally water tank system, water meter ❖ Painted in polyurethane paint – one colour barrel one colour frame 	<ul style="list-style-type: none"> ❖ 2 colour barrel ❖ 300L water tank ❖ Remote switch chute lock operation ❖ LED light bar work light ❖ Water gun both sides ❖ Trailer legs
STANDARD STEERABLE BTE TRAILER	
<ul style="list-style-type: none"> ❖ Chassis: Manufactured principally from Domex 700MPA high strength steel, pressed Domex suspension and chassis cross members, tapered rear chassis section. ❖ Skidplate: Oscillating skidplate with 50mm kingpin. ❖ Axles: Two off SAF Disc brake steer axles fitted with VSE electro hydraulic steering system and remote control, axles fitted with 10 stud 335mm PCD hubs and disc brakes one fixed non steer axle in front location complete with lift function. ❖ Suspension: SAF Module airbag suspension ❖ Brake control: Knorr Bremse EBS triaxle brake kit, with quick release couplings mounter on front bulkhead. ❖ Electrical: Full wiring loom with LED stop, tail and indicators including plug in loom extension for three off (3) Narva clearance lights per side one centre indicator mounted off chassis. ❖ Landing Legs: Mounting provision only. ❖ Painting: All steel work cleaned, primed and painted in 2 K to match fleet colours. ❖ Wheels and tyres: 6 off 10 stud 335mm PCD polished aluminum wheels with Haulmax tubeless 385/65R22.5 tyres fitted. ❖ Mudguards: Pressed aluminum chequer plate with centre infill, stainless steel handrails and fold down ladders on each side. 	

Advances in design or improvements in materials are incorporated without delay, consequently we reserve the right to alter details given on this specification sheet without notice. Operating weight and centre of gravity may vary depending on selected options.



Specification

STEERABLE "SUPA MAXI"

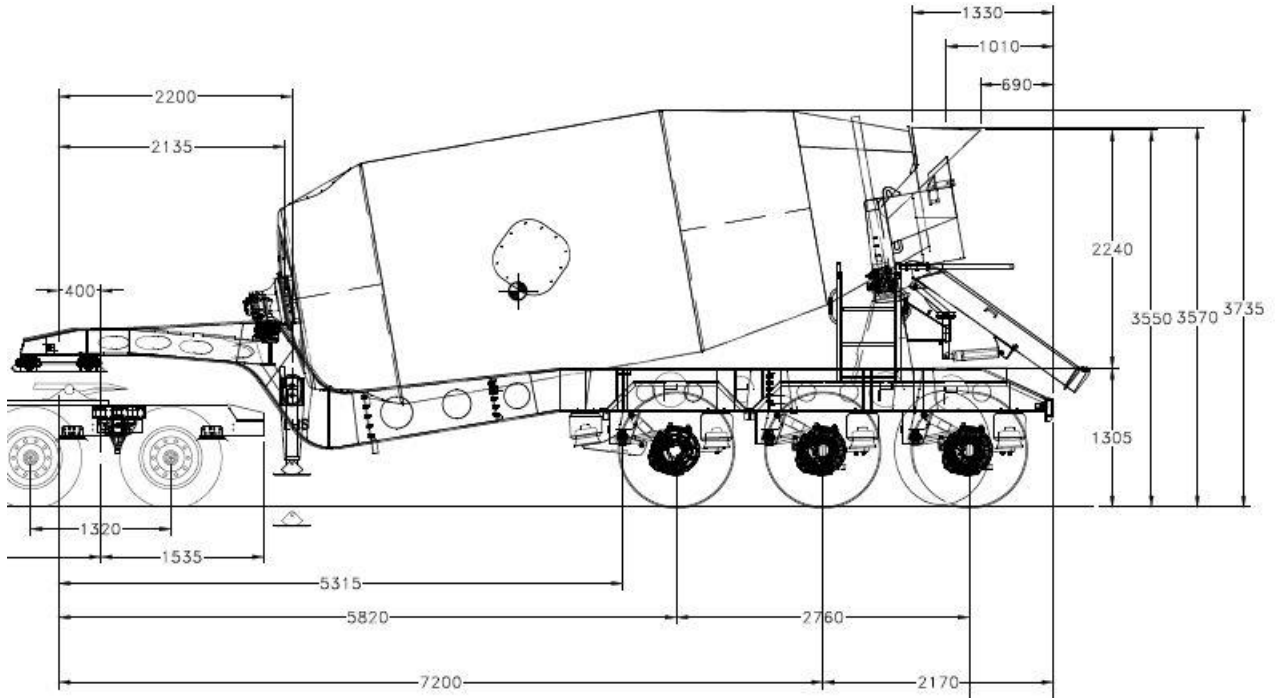

Item	Description	11.5 m ³
1	Operating Weight (approx.) until final specification "Steerable Axles" developed and Prime mover type.	8,900kgs plus water
2	Total Barrel Volume	17.8 m ³
3	Mixing Capacity to AS1379 – 1991	11.5 m ³
4	Gearbox	ZF 7300
5	Hydraulic Pump	130cc/rev
6	Hydraulic Motor	75cc/rev
7	Water System	200 litre alloy p.w.s.
8	Controls	Remote
9	Trunnion Rollers	4 x Steel
10	Chutes – 2 x Extension, 1 x Placement	Poly
11	Front trailer axle	Lift function
12	Middle trailer axle	Steerable up to 26°
13	Rear trailer axle	Steerable up to 26°

Cesco Australia Limited

Brisbane: Head Office
 Mixer Service Centre: 38 Goodman Place Murarrie Qld 4172 Ph: 07 3908 6088 F: 07 3390 6898
 Melbourne: Mixer Service Centre: 76-78 Hallam South Road Hallam Vic 3903 Ph: 03 9796 4977 F: 03 9796 4811

Note: Specifications and mixer layout are for references only and subject to actual applications and components availability.

www.cescoaustralia.com